



ETA-Danmark A/S
Göteborg Plads 1
DK-2150 Nordhavn
Tel. +45 72 24 59 00
Internet
www.etadanmark.dk

Authorised and notified according
to Article 29 of the Regulation (EU)
No 305/2011 of the European
Parliament and of the Council of 9
March 2011

MEMBER OF EOTA



European Technical Assessment ETA-21/0825 of 2022/01/06

General Part

Technical Assessment Body issuing the ETA and designated according to Article 29 of the Regulation (EU) No 305/2011: ETA-Danmark A/S

Trade name of the
construction product:

KOMPROMENT cladding kit type Pantheon Earth,
Colosseum Earth and Concrete Cover

Product family to which the
above construction product
belongs:

Kits for external wall claddings mechanically fixed

Manufacturer:

KOMPROMENT
Jellingvej 11
9230 Svenstrup
Tel. + 45 96520710
Internet www.komproment.dk

Manufacturing plant:

KOMPROMENT
Jellingvej 11
9230 Svenstrup

This European Technical
Assessment contains:

16 pages including 9 annexes which form an integral
part of the document.

This European Technical
Assessment is issued in
accordance with Regulation
(EU) No 305/2011, on the
basis of:

EAD 090062-00-0404 – Kits for external wall claddings
mechanically fixed

This version replaces:

The ETA with the same number issued on 2021-10-02

Translations of this European Technical Assessment in other languages shall fully correspond to the original issued document and should be identified as such.

Communication of this European Technical Assessment, including transmission by electronic means, shall be in full (excepted the confidential Annex(es) referred to above). However, partial reproduction may be made, with the written consent of the issuing Technical Assessment Body. Any partial reproduction has to be identified as such

II SPECIFIC PART OF THE EUROPEAN TECHNICAL ASSESSMENT

1 Technical description of the product

The KOMPROMENT Cladding kit type Pantheon Earth, Colosseum Earth and Concrete Cover consist of cladding elements that are suspended on the subframe by means of a hook-on arrangement with slotted fixings and the cladding fixings are hook/slot profile and rails or other similar fixings

The kit consists of the following elements:

Subframe: Vertical 25 mm aluminium subframe, 25 mm and horizontal aluminium subframe both alloy AW 6060 according to EN 775.

Screws for fixing the horizontal aluminium subframe to the vertical subframe: 4,8 x 20 mm stainless steel A2 self-tapping screws

Support clips for cladding elements: stainless steel clips. Grade 1.4301 in accordance with EN 10088-1 2,5 mm wide and 1,25 mm thick with

Cladding element: Pantheon Earth and Colosseum Earth: 100 % ceramic tiles. CE marked in accordance with EN 1304.

Cladding element Concrete Cover: Concrete tiles. CE marked in accordance with EN 490

Dimensions and material parameters are specified in annex A.

The metal fasteners for fixing the horizontal subframe into the substrate is not a part of the kit

2 Specification of the intended use(s) in accordance with the applicable European Assessment Document (hereinafter EAD)

The construction product KOMPROMENT Cladding kit type Pantheon Earth, Colosseum Earth and Concrete Cover is intended for use as fastening of external wall claddings, in ventilated facades.

The cladding kits are fixed to external vertical walls made of masonry (clay, concrete, or stone), concrete (cast on site or as prefabricated panels), timber or metal frame in new or existing buildings (retrofit)

The façade kit is assessed as a kit family G in accordance with EAD 090062-00-0404.

The verification and assessment methods on which this European Technical Assessment is based lead to the assumption of a working life of 25 years, when installed in the works.

The indications given as to the working life of the construction product cannot be interpreted as a guarantee neither given by the product manufacturer or his representative nor by the Technical Assessment Body issuing an ETA based on the EAD 090062-00-0404 but are regarded only as a means for expressing the expected economically reasonable working life of the product.

3 Performance of the product and references to the methods used for its assessment

Characteristic	Assessment of characteristic
3.2 Safety in case of fire (BWR 2)	
Reaction to fire	The metal parts and the clay tiles of the KOMPROMENT Cladding kit type Pantheon Earth, Colosseum Earth and Concrete Cover are classified as Euroclass A1 in accordance with EN 13501-1 and Delegated Regulation 2016/364
Façade fire performance	No performance assessed
Propensity to undergo continuous smoldering	Not relevant
3.3 Hygiene, health and the environment (BWR 3)	
Watertightness of joints (protection against driving rain)	Not watertight
Water absorption (for non-ventilated facades)	Not relevant
Water vapour permeability (for non-ventilated facades)	Not relevant
Drainability	See figures in annex 2
Content, emission and/or release of dangerous substances	The cladding kit and its components does not contain/release dangerous substances specified in EOTA GD14*
3.4 Safety and accessibility in use (BWR 4)	
Wind load resistance	Colosseum Earth: 1.800 Pa Pantheon Earth: 2.200 Pa Concrete Cover: 2400 Pa No failure occurred. The joints in the tiles did not allow for obtaining higher pressure. The characteristic wind resistance of the kit is governed by the resistance of slot/hinge – see below
Resistance to horizontal point loads	No visible deformation on any component observed
Impact resistance	Kits with Concrete Cover: Impact category II. Kits with Colosseum Earth and Pantheon Earth: No Performance assessed

Characteristic	Assessment of characteristic
Mechanical resistance of:	
Cladding element	<p>Bending strength: Colosseum Earth No Performance assessed</p> <p>Pantheon Earth No performance assessed</p> <p>Concrete Cover No performance assessed</p>
Resistance of slot/hinge	<p>Colosseum Earth F_c: 745 N pr tile Characteristic resistance of the kit: 8.05 kN/m² with 10.8 tiles per m²</p> <p>Pantheon Earth F_{mean}: 754 N pr tile Characteristic resistance of the kit: 8.14 kN/m² with 10.8 tiles per m²</p> <p>Concrete Cover F_{mean}: 791 N pr tile Characteristic resistance of the kit: 9,65 kN/m² with 12,2 tiles per m²</p>
Resistance of profiles	<p>0,2% yield strength R_{p0,2} = 160 N/mm² Tensile strength: R_m = 215 N/mm² Elongation at break: A₅₀ = 8% Modulus of elasticity: E = 70.000 N/mm²</p>
Tension/pull out resistance of subframe fixings	<p>The resistance of the slot is the determining factor and therefore the tension/pull out resistance equals the resistance of the slots.</p>
3.5 Protection against noise (BWR 5)	
Airborne sound insulation	No performance assessed
3.6 Energy economy and heat retention (BWR 6)	
Thermal resistance	No performance assessed
3.7 Durability	
Hygrothermal behavior	Not relevant. The cladding element is not known to be or suspected of being sensitive to hygrothermal variation
Behavior after pulsating load	Not relevant. The cladding kit is not known to be or suspected of being sensitive to pulsating load
Freeze-thaw resistance	Pantheon Earth has been tested in accordance with EN 539-2 and showed no damage after 150 freeze/thaw cycles
Behavior after immersion of water	Not relevant. The cladding element is not known to be or suspected of being sensitive to water

Characteristic	Assessment of characteristic
Dimensional stability: By humidity	Not relevant. The cladding element is not known to be or suspected of being sensitive to humidity
By temperature	Not relevant The cladding element is not known to be or suspected of being sensitive to temperature
Chemical and biological resistance	Not relevant. The cladding kit is made from inorganic materials
UV radiation resistance	Not relevant. The cladding kit does not contain polyester or other plastics
Corrosion	The durability rating of alloy AW 6060 in accordance with EN 1999-1-1 is B Normally additional corrosion protection is not needed for atmospheric exposure in rural, industrial/urban and marine conditions according to table D.1 of EN 1999-1-1

*) In accordance with <http://europa.eu.int/-/comm/enterprise/construction/internal/dangsub/dangmain.htm> In addition to the specific clauses relating to dangerous substances contained in this European Technical Assessment, there may be other requirements applicable to the products falling within its scope (e.g. transposed European legislation and national laws, regulations and administrative provisions). To meet the provisions of the EU Construction Products Regulation, these requirements need also to be complied with, when and where they apply.

***) See additional information in section 3.8 – 3.9.

3.8 Methods of verification

The product is fully covered by EAD 090062-00-0404. According to the Regulation (EU) No 305/2011.

3.9 General aspects related to the fitness for use of the product

The European Technical Assessment is issued for the product based on agreed data/information, deposited with ETA-Danmark, which identifies the product that has been assessed and judged. Changes to the product or production process, which could result in this deposited data/information being incorrect, should be notified to ETA-Danmark before the changes are introduced. ETA-Danmark will decide if such changes affect the ETA and consequently the validity of the CE marking based on the ETA and if so whether further assessment or alterations to the ETA, shall be necessary.

The KOMPROMENT cladding kits type Pantheon Earth, Colosseum Earth and Concrete Cover are manufactured in accordance with the provisions of this European Technical Assessment using the manufacturing processes as identified in the inspection of the plant by the notified inspection body and laid down in the technical documentation

4 Assessment and verification of constancy of performance (hereinafter AVCP) system applied, with reference to its legal base

4.1 AVCP system

According to the decision 2003/640/EC of the European Commission, as amended by 2001/596/EC, the system(s) of assessment and verification of constancy of performance (see Annex V to Regulation (EU) No 305/2011) is 2+.

5 Technical details necessary for the implementation of the AVCP system, as provided for in the applicable EAD

Technical details necessary for the implementation of the AVCP system are laid down in the control plan deposited at ETA-Danmark prior to CE marking.

Issued in Copenhagen on 2022-01-06 by



Thomas Bruun
Managing Director, ETA-Danmark

COLOSSEUM Earth - 225x440 mm

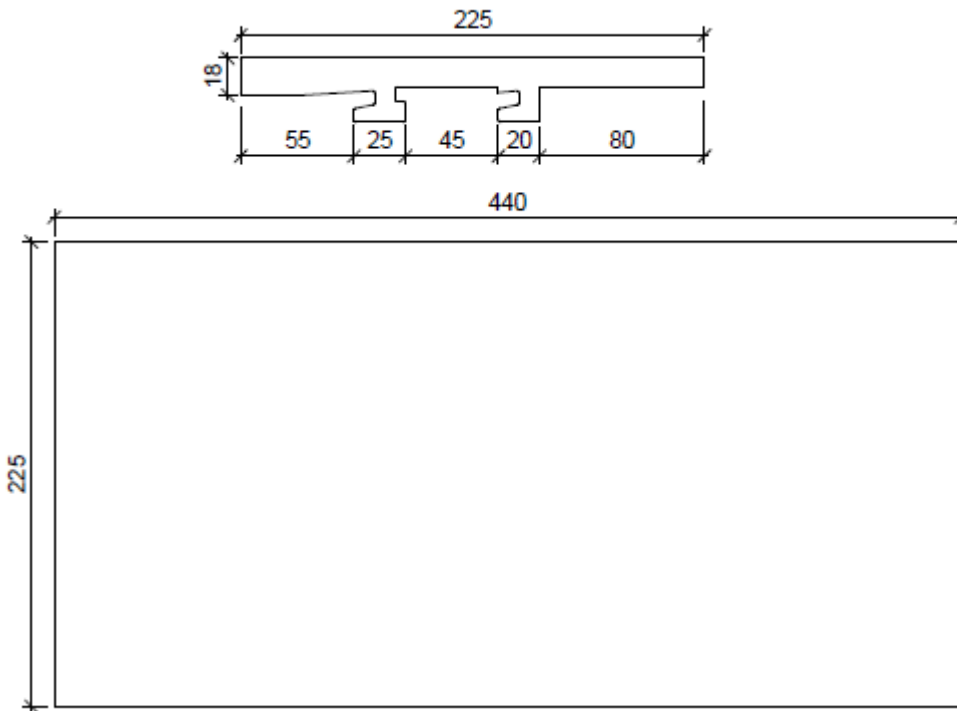

Pantheon Earth

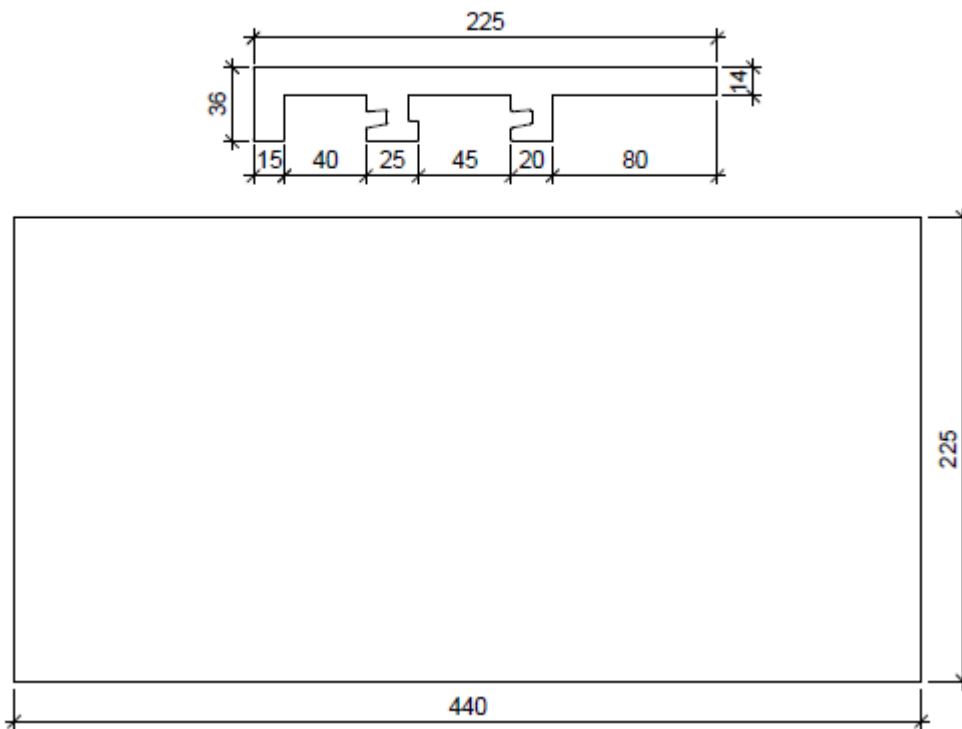

KOMPROMENT cladding kit type Pantheon Earth, Colosseum Earth and Concrete Cover

Annex 1

Cladding elements

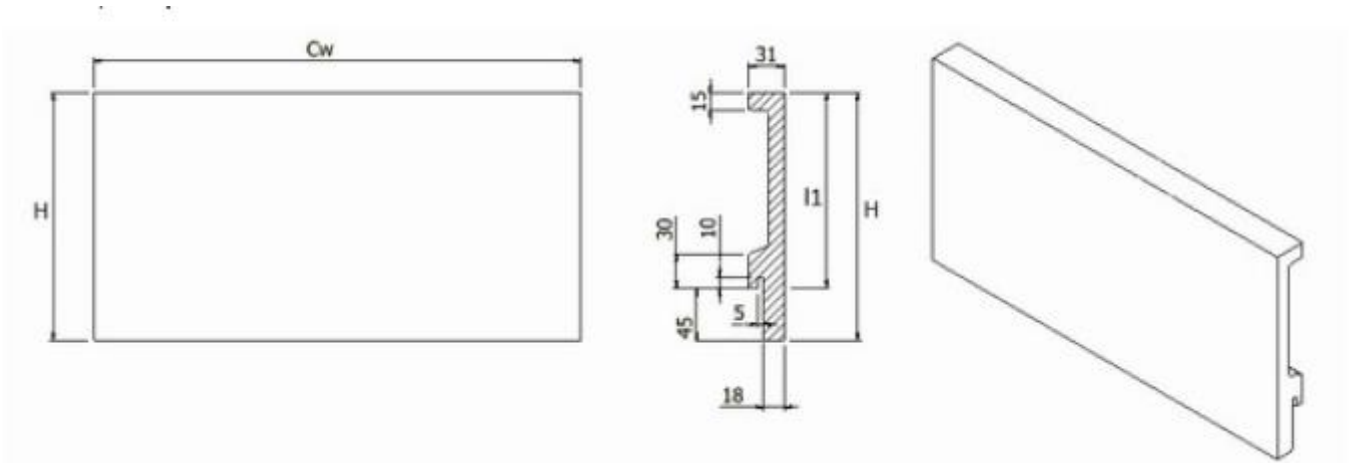

Length, L1: 170 mm ± 4 mm
 Width, Cw: 420 mm ± 3 mm
 Thickness: Top 18 mm, bottom 14 mm
 Squareness < 4 mm
 Class T5 according to EN 490
 Water absorption ≤ 7%

<p>KOMPROMENT cladding kit type Pantheon Earth, Colosseum Earth and Concrete Cover</p>	<p>Annex 2</p>
<p>Cladding elements</p>	

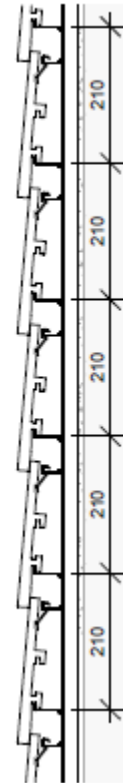
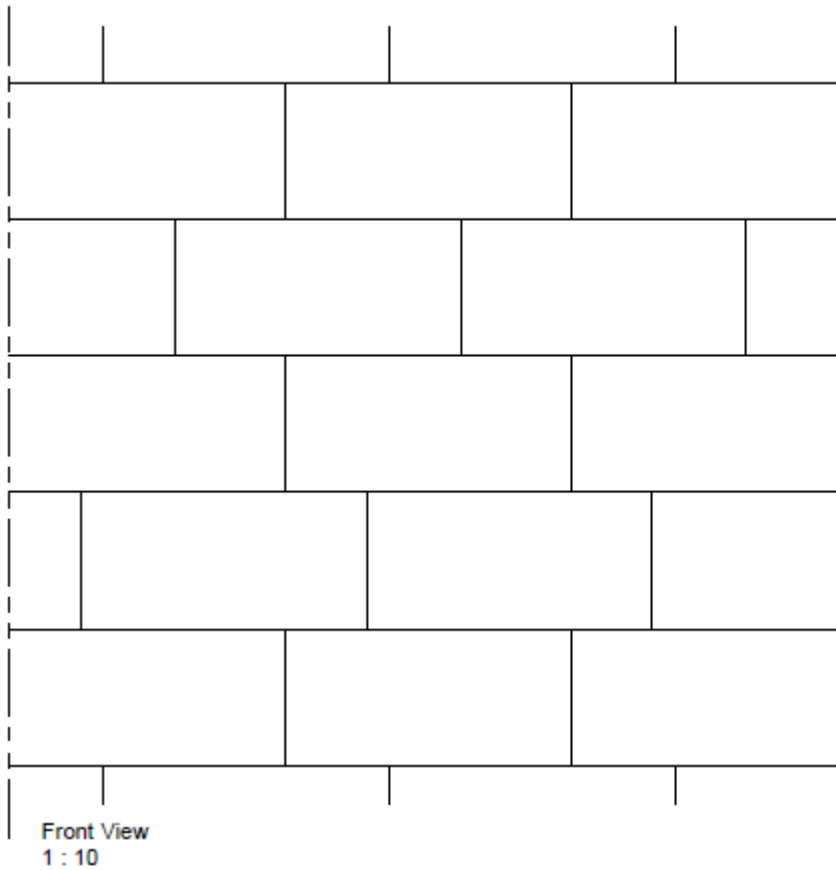

Colosseum Earth tiles is a rough ceramic product and has the small distinctive features that characterise this natural product. There will be variation in the surface and size of each tile.
The following points must be observed to achieve optimal results:

- Colosseum Earth tiles MUST be mixed from multiple pallets to achieve the desired color variation (Min 4-6 pallets).
- Colosseum Earth is a ceramic product and breakage on corners and edges will appear as a natural part of the tiles.
- Recommended bond: Wild bond.
- Recommended minimum tile width for adjustments = 100 mm
- Max batten distance: 210 mm (Standard)
- Minimum batten distance: 190 mm

Gluing of tiles:

In situations where the use of Komproment façade adhesive is required, it is important to always glue tile to tile.

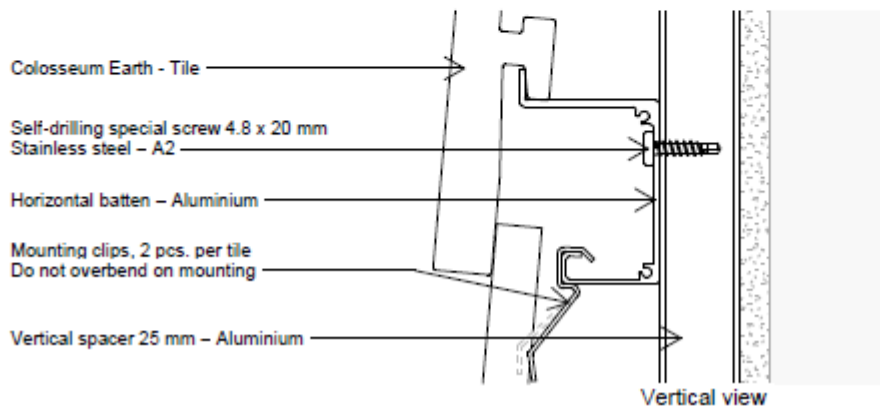

<p>KOMPROMENT cladding kit type Colosseum Earth</p>	<p>Annex 3</p>
<p>Drainability</p>	

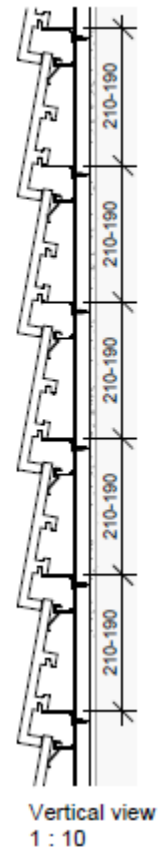
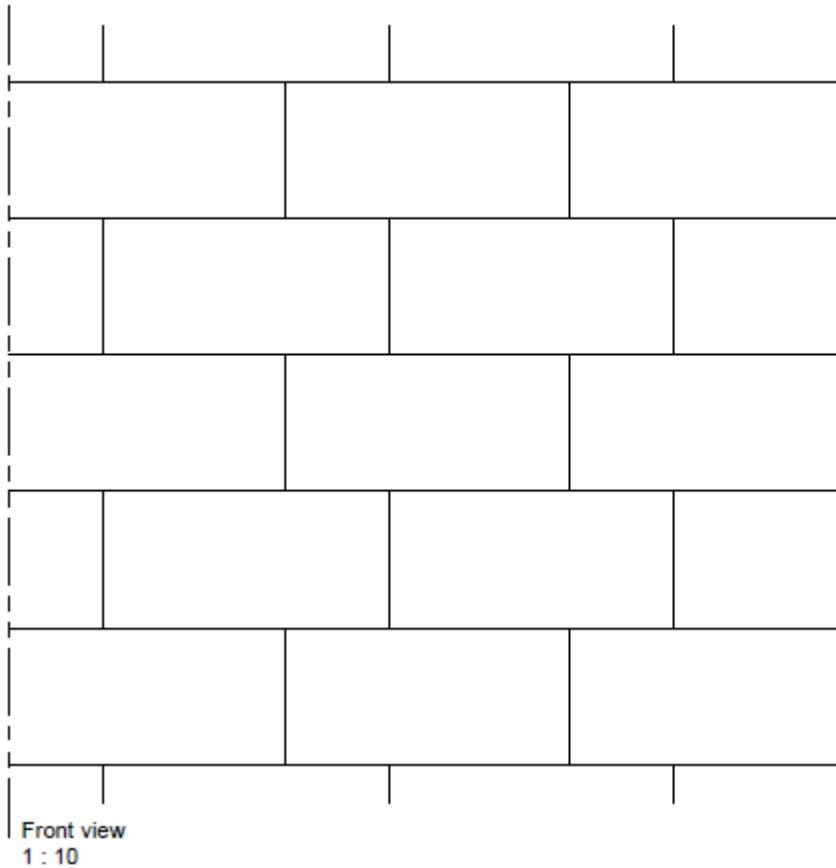

Pantheon Earth tiles is a rough ceramic product and has the small distinctive features that characterise this natural product. There will be variation in the surface and size of each tile.

The following points must be observed to achieve optimal results:

- Pantheon Earth tiles MUST be mixed from multiple pallets to achieve the desired color variation (Min 4-6 pallets).
- Pantheon Earth is a ceramic product and breakage on corners and edges will appear as a natural part of the tiles.
- Recommended bond: Wild bond.
- Recommended minimum tile width for adjustments = 100 mm
- Max batten distance: 210 mm (Standard)
- Minimum batten distance: 190 mm

Gluing of tiles:

In situations where the use of Komproment façade adhesive is required, it is important to always glue tile to tile.

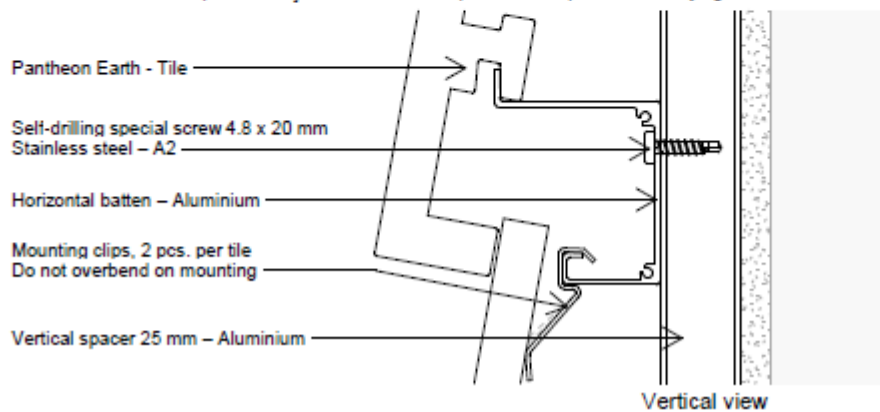

<p>KOMPROMENT cladding kit type Pantheon Earth</p>	<p>Annex 4</p>
<p>Drainability</p>	

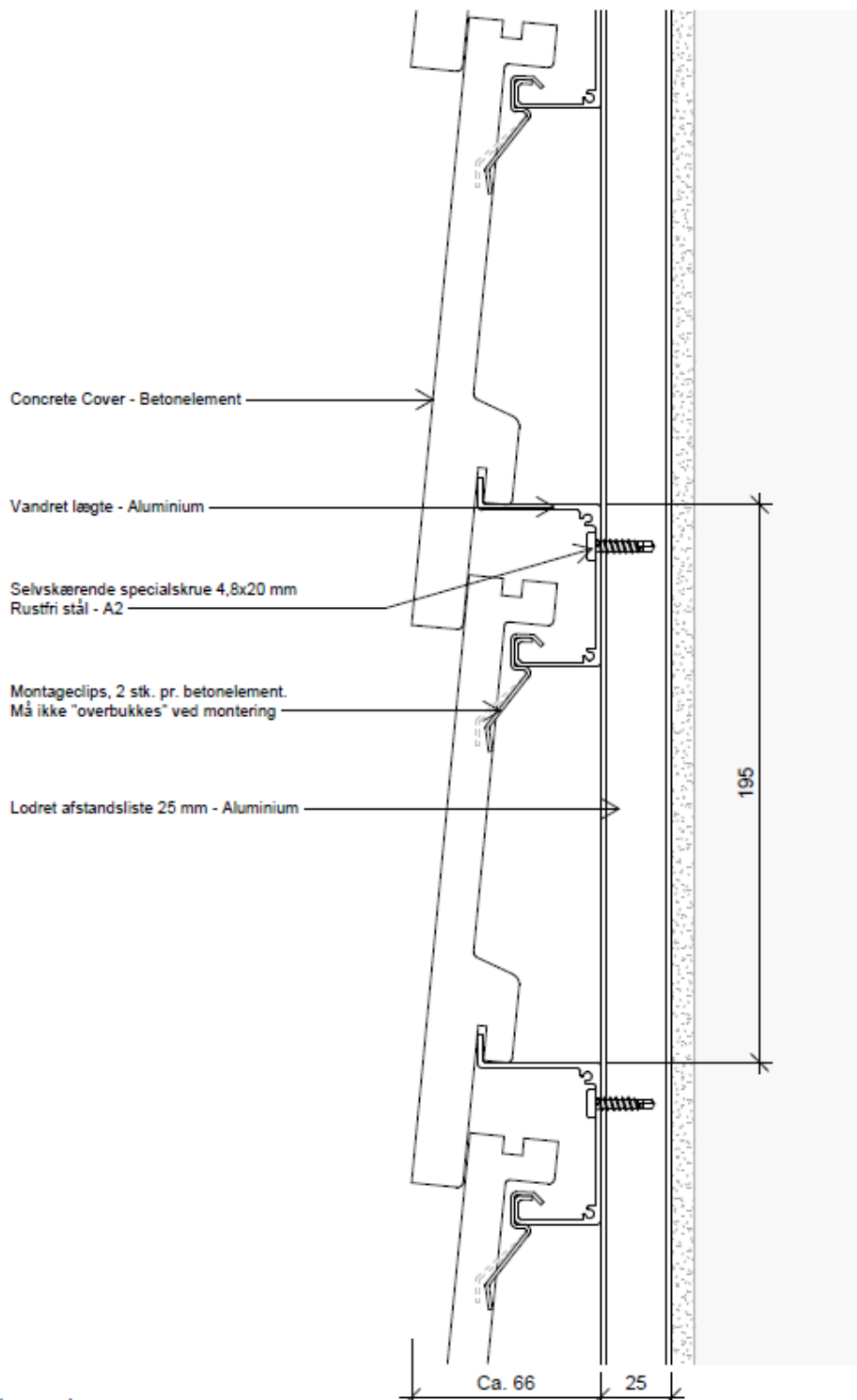

KOMPROMENT cladding kit type Concrete Cover

Annex 5

Drainability

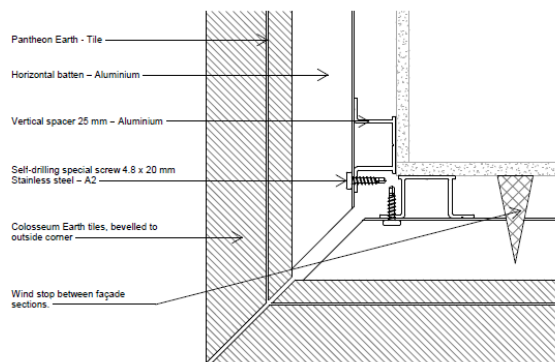
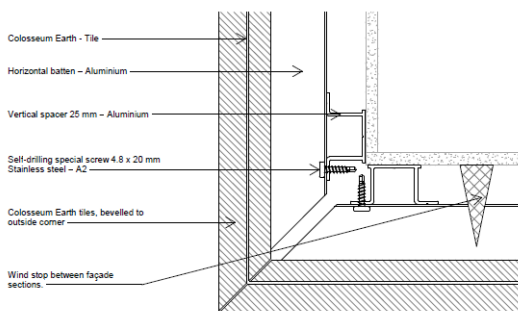
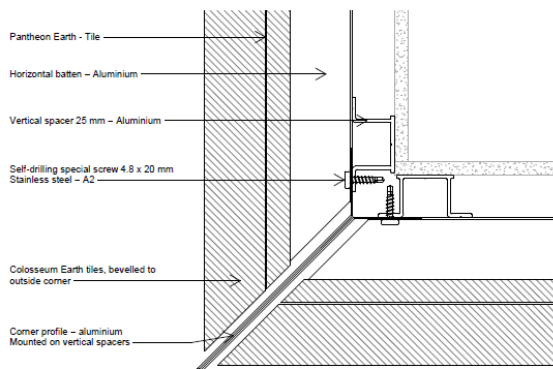
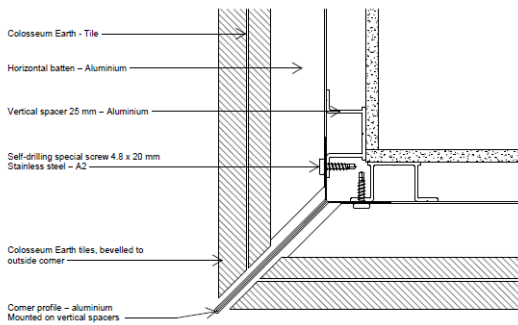
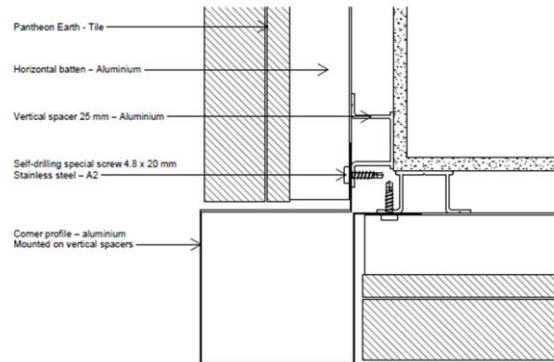
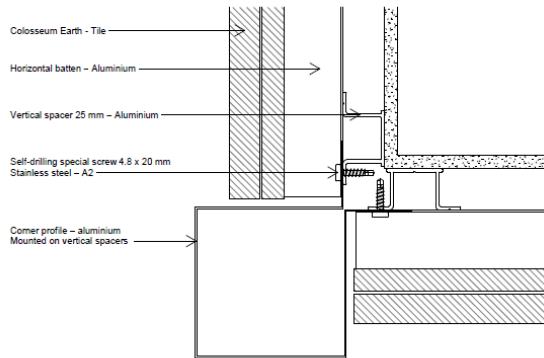
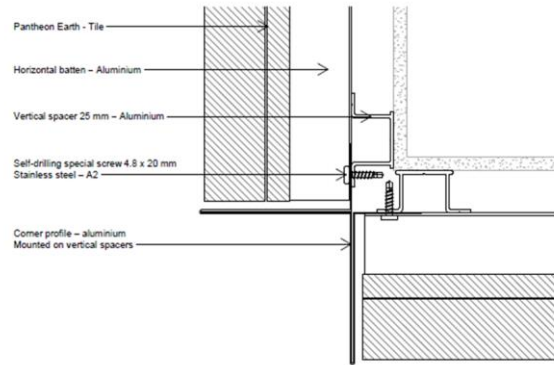
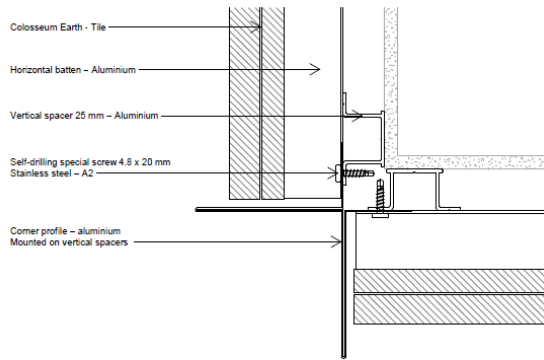

KOMPROMENT cladding kit type Pantheon Earth, Colosseum Earth and Concrete Cover

Annex 6

Installation examples
Corner with siding – horizontal installation

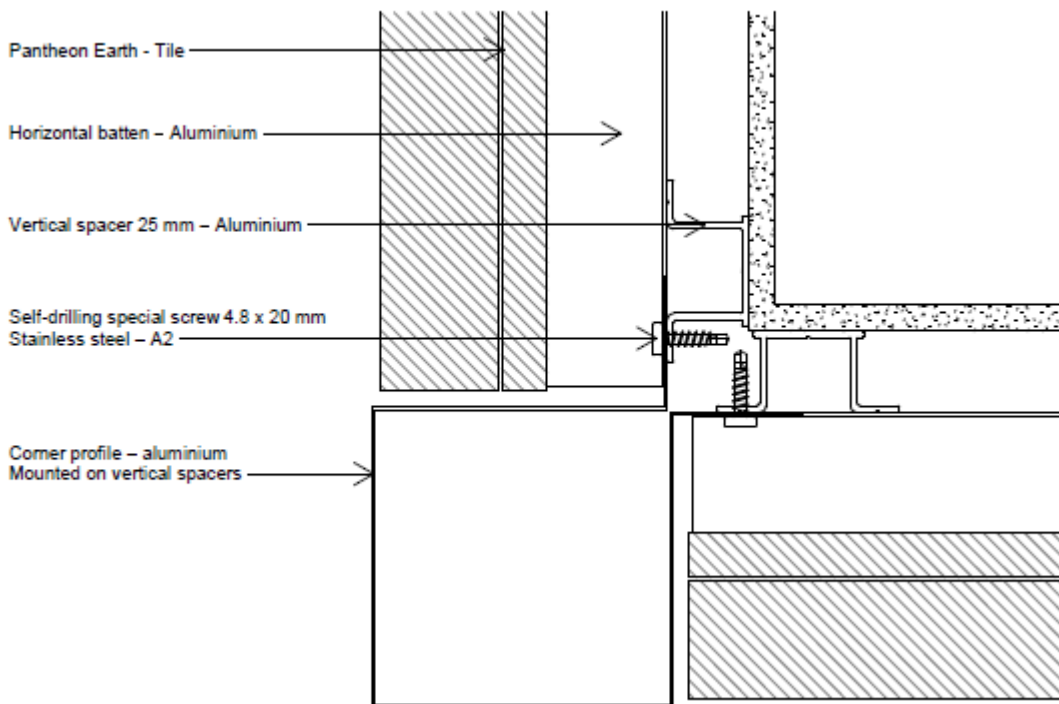
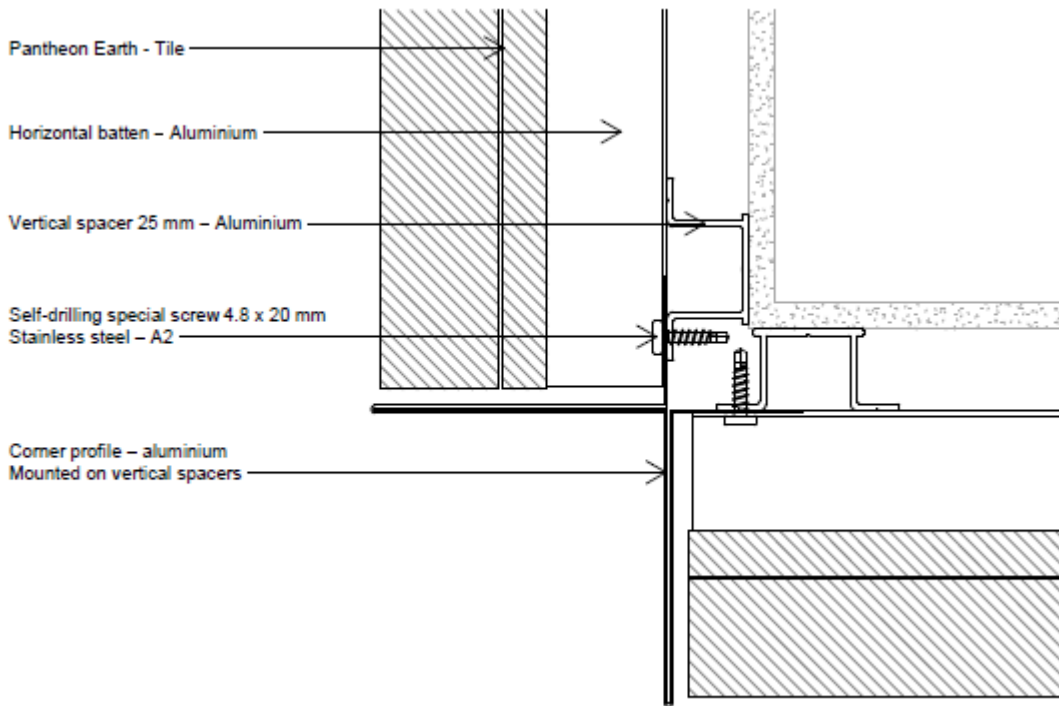

KOMPROMENT cladding kit type Pantheon Earth, Colosseum Earth and Concrete Cover

Annex 7

Installation examples
Corner with siding – horizontal installation

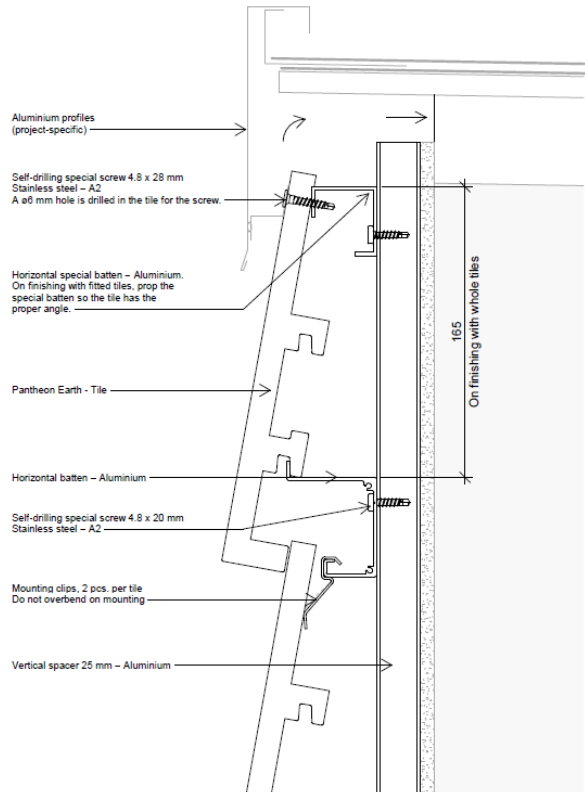
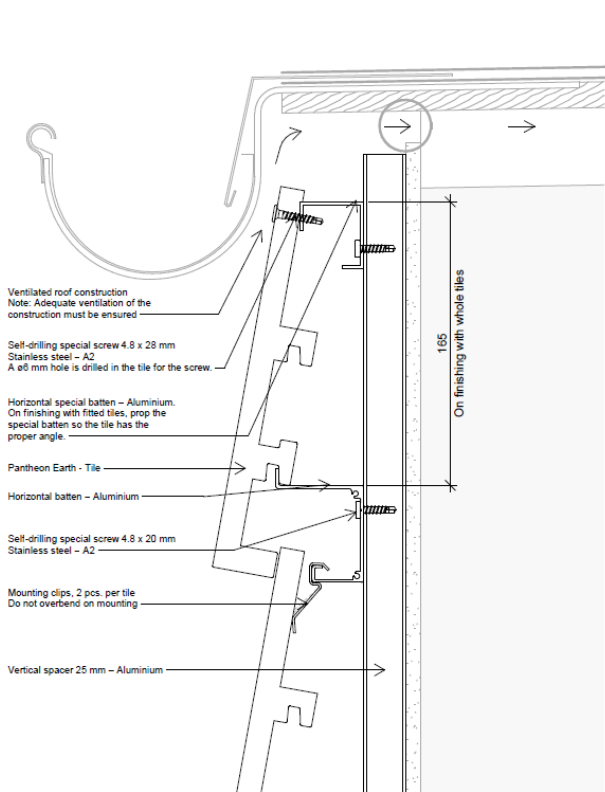
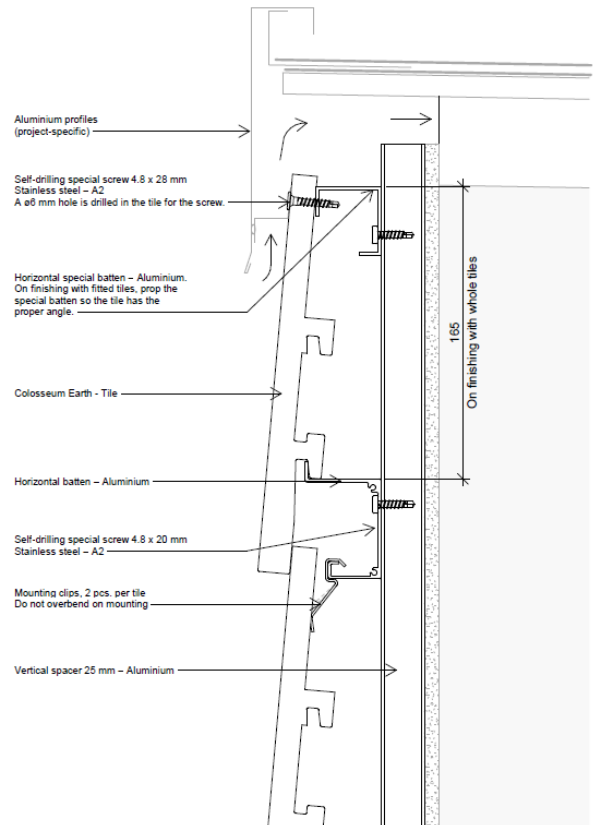
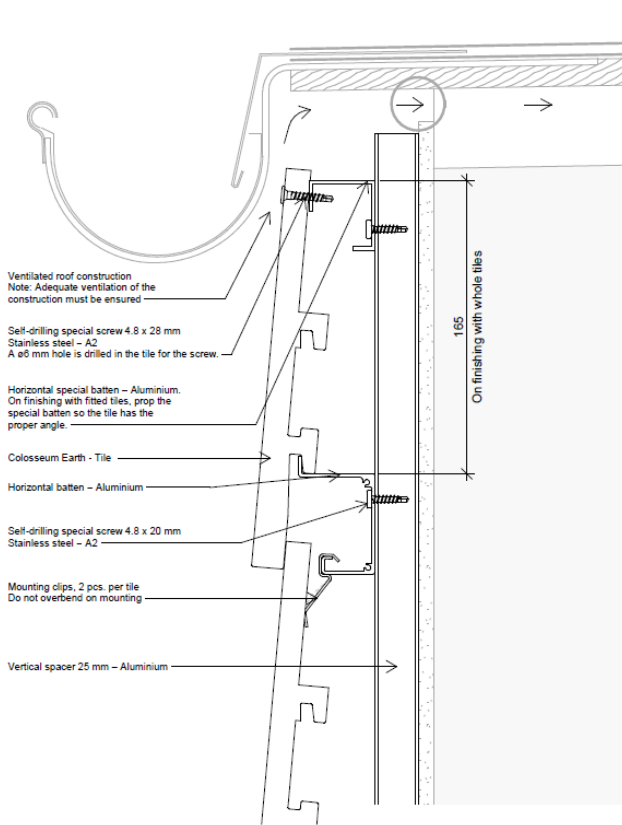

KOMPROMENT cladding kit type Pantheon Earth, Colosseum Earth and Concrete Cover

Installation examples
Attic – vertical installation

Annex 8

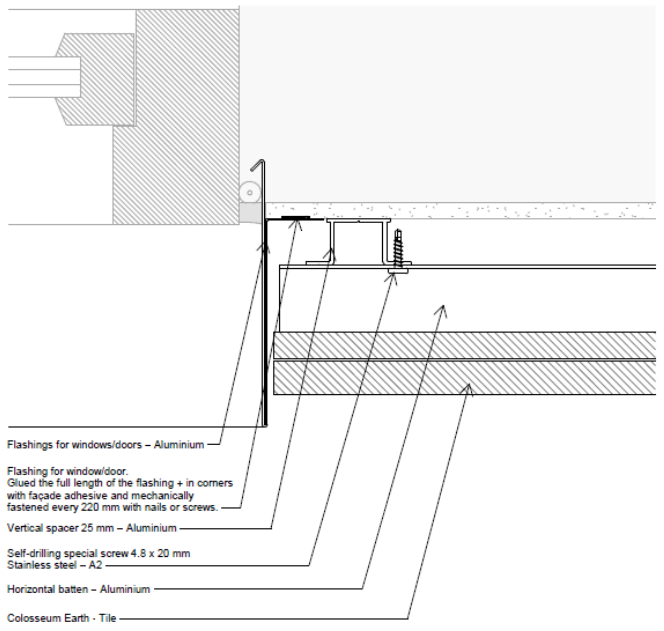
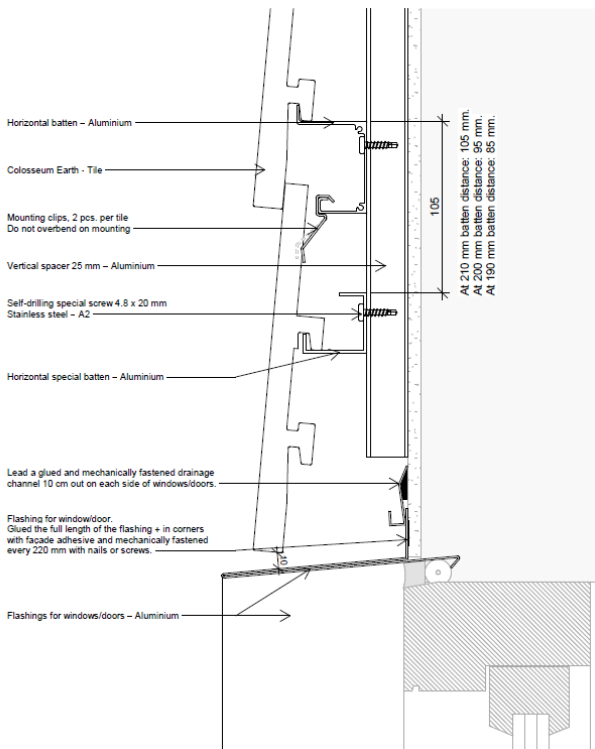
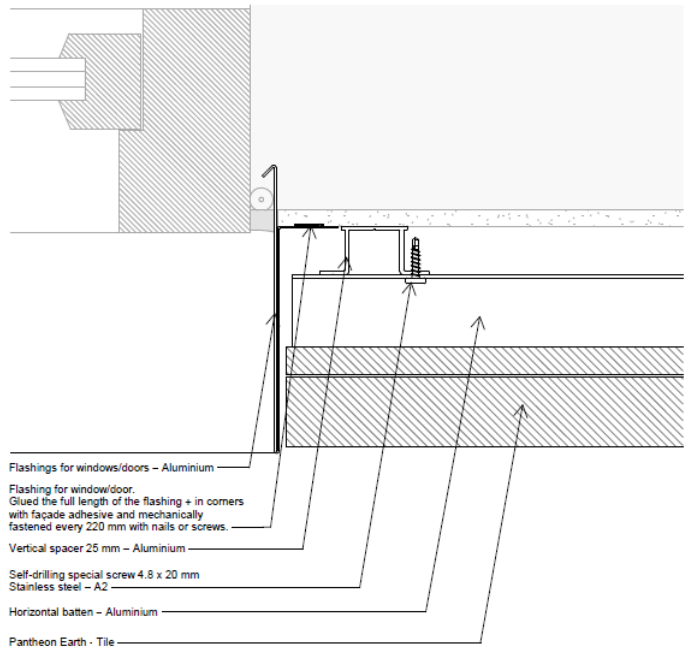
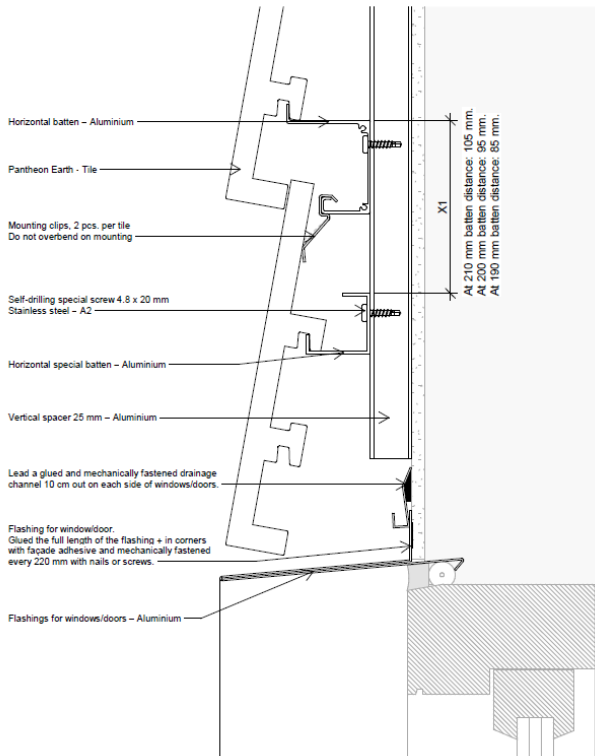

KOMPROMENT cladding kit type Pantheon Earth, Colosseum Earth and Concrete Cover

Annex 9

Installation examples

Side window connection – vertical and horizontal installation

$I_y=76888 \text{ mm}^4$
 $I_x=161528 \text{ mm}^4$
 $E_y=34,37 \text{ mm}$
 $E_x=34,92 \text{ mm}$

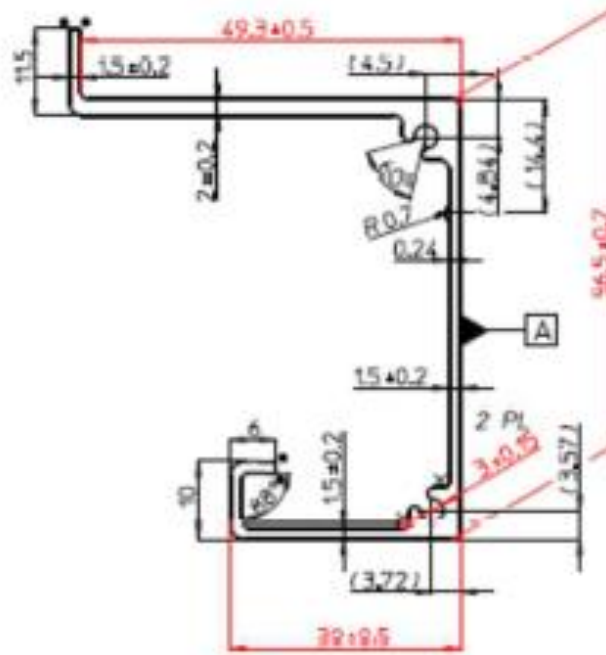

KOMPROMENT cladding kit type Pantheon Earth, Colosseum Earth and Concrete Cover	Annex 10
Horizontal subframe	

Design

The design of the external wall claddings for ventilated facades using the KOMPROMENT cladding kit type Pantheon Earth, Colosseum Earth and Concrete Cover should consider:

- It is assumed that the substrate wall meets the necessary requirements regarding the mechanical strength (resistance to static and dynamic loads) and the airtightness, as well as the relevant resistance regarding watertightness and water vapour.
- The verification of the designed system by means of calculation, taking into account the mechanical characteristic value of the kit components in order to resist the actions (dead loads, wind loads etc.) applying on the specific works. National safety factors and other national provisions must be followed.
- The selection and verification of the brackets which support the subframe vertical profiles considering compatible materials (e.g. aluminium alloy) and the mechanical resistance (vertical and horizontal resistance) according to the envisaged actions obtained from the mechanical calculation of the designed system.
- The selection and verification of the anchors between the brackets and the external walls (substrate), taking into account the substrate material and the minimum resistance required (pull-out and shear resistance) according to the envisaged actions obtained from the mechanical calculation of the designed system.
- The accommodation of the designed system movements to the substrate or structural movements.
- The execution of singular parts of the façade, some examples of construction details are indicated in annex 3.
- The corrosion protection of the designed system metallic components taking into account the category of corrosivity of the atmosphere of the works (e.g. according to ISO 9223).
- The drainability of the ventilated air space between the cladding elements and the insulation layer or the external wall accordingly.
- An insulation layer is usually fixed on the external wall and should be defined in accordance with an harmonized standard or an ETA and taking into account the section 3 of this ETA.
- Because the joints are not watertight, the first layer behind the ventilated air space (e.g. insulation layer) should be composed by materials with low water absorption.

Installation

Installation of the external wall claddings for ventilated facades using the KOMPROMENT cladding kit type Pantheon Earth, Colosseum Earth and Concrete Cover should be carried out:

- According to the specifications of the manufacturer and using the components specified in this ETA.
- In accordance with the design and drawings prepared for the specific works. The manufacturer should ensure that the information on these provision is given to those concerned.
- By appropriately qualified staff and under the supervision of the technical responsible of the specific works.

Maintenance and repair

Maintenance of the external wall claddings for ventilated facades using the KOMPROMENT cladding kit type Pantheon Earth, Colosseum Earth and Concrete Cover includes inspections on site, taking into account the following aspects:

- Regarding the cladding elements, the appearance of any damage such as cracking, detachment, delamination and mould presence due to permanent moisture or permanent irreversible deformation.
- Regarding metallic components: The presence of corrosion or presence of water accumulation.

When necessary, any repair to localized damaged areas must be carried out with the same components and following the repair instructions given by the manufacturer.

<p>KOMPROMENT cladding kit type Pantheon Earth, Colosseum Earth and Concrete Cover</p>	<p>Annex 11</p>
<p>Design, installation, maintenance, and repair criteria</p>	